

400+ X-RAY INSPECTION

Explosives, Weapons and Contraband

SINGLE SOURCE, MULTI-ENERGY

X-RAY INSPECTION



The single-source, multi-energy 400+ X-ray inspection system is designed to screen small- to mid-sized items for weapons, explosives, drugs and other contraband. The right size for scanning strollers, briefcases, backpacks, purses and other hand-carried items, this compact workhorse is ready to meet the toughest throughput demands.

With a trim footprint, the user-friendly 400+ delivers best-in-class speed and detection capability and makes the most of available space.

- > Rapidly images full mailbags and long or tall items
- > Fits in elevators, narrow halls and tight spaces
- > Patented guided conveyor belt never needs adjusting
- > Built on the industry's most stable and flexible operating system

APPLICATIONS:

- > Schools
- > Courthouses
- > Police Stations
- > Executive Offices
- > Mailrooms

400+ SPECIFICATIONS

X-RAY INSPECTION

PHYSICAL DETAILS

Tunnel Size:	62.0 x 42.0 cm 24.4 x 16.5 in. (W x H)
Dimensions:	154.6 x 80.9 x 126.4 cm 60.9 x 31.9 x 49.8 in. (L x W x H)
Weight:	268 kg (590 lbs.) uncrated 363 kg (800 lbs.) crated
Construction:	Unibody heavy gauge epoxy painted steel construction with stainless steel and aluminum trim and accessories; non-marking casters
Temperature:	0° to 40°C (32° to 104°F)
Humidity:	20% to 95%, non-condensing
Storage:	To 65°C (149°F)
Power Consumption:	< 0.8 kVA; < 8 amps 100, 120 volts AC ±10%; < 4 amps 200, 220, 230, 240, 250 volts AC ±10%; all at 50 or 60 Hz

X-RAY GENERATOR

X-ray Tube Head:	Self-contained with sealed oil bath cooling
High Voltage Rating:	100 kV, operating at 90 kV
Duty Cycle:	100% with sealed oil bath cooling
Beam Orientation:	Diagonal (80° beam divergence)
Dose Per Exam:	0.1 mR

INSPECTION CAPABILITIES

Material Penetration:	10 mm (0.39 in.) steel
Contrast Sensitivity:	Over 2 million color tones standard
Resolution:	40 AWG wire
Processing:	32-bit adaptive image processing with minimum 128 Mbytes memory; 2.4+ GHz processor
Conveyor Speed:	24.0 cm (9.4 in.) per second 14.6 m (48 ft.) per minute
Pulling Weight:	150 kg (331 lbs.)
Film Safety:	Guaranteed for high-speed film up to ISO 1600 (33 DIN)

DETECTORS

L-shaped detector for 100% object screening
Surface mounted, multilayer, fully integrated, high frequency solid state detectors using high speed processors and Pentium 4 image processing

VIDEO

Color 19" monitor, 1280 x 1024 video card

STANDARD FEATURES

- autoSoft operating system
- Full-size operator control panel (OCP) with touchpad navigation
- autoTracking guided conveyor belt system
- Reversible conveyor direction
- High/low density and stripping
- Organic/inorganic stripping
- Color; reverse B/W imaging
- Interactive, user-friendly help screens
- 128x Smart Zoom
- D-SCAN
- Dark and light enhance
- RealClear
- autoDensAlert
- autoOutline
- autoSensing
- autoScale
- autoCal
- Save screen to USB
- Z-SCAN
- autoImage recall (10 images)
- Adjustable zoom preview window

OPTIONS

- Loading or exit rollerbeds
- Conveyor extensions
- Tropical humidity kit
- DVD drive
- autoShieldAlert
- autoZ display
- Image archiving (500K)
- Threat image projection (TIP)
- Built-in training
- Level 1, 2 and 3 networking
- User management
- Remote operation
- autoArchive
- Item counter
- Locking metal OCP cover
- Variable height OCP mount
- Dual and larger monitors
- Monitor platform
- Locking monitor garage
- Laser printer
- Console desk
- kV, mA meter
- Power conditioner, or UPS
- Optical X-ray on/off sensor
- Footpad
- STI Viewer software for archived image analysis

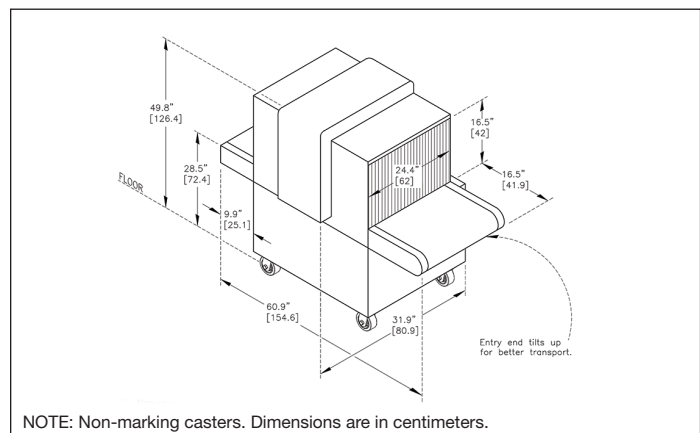

World Headquarters
10A Bloomfield Avenue
Pine Brook, NJ 07058 USA

Tel. 1 973.276.6000
1 973.276.6161
Fax. 1 973.227.0832
info@autoclear.com

ISO 9001-2015 REGISTERED

© 2011-2019 Autoclear. CheckGate®, Control Screening®, Dynavision®, HandWand® and Scintrex® are among our many registered trademarks. All rights reserved. Autoclear reserves the right to update this information presented in this document at any time, without notice.